

Arena Ripper
Model AR-520
(With Wheeled Transport)

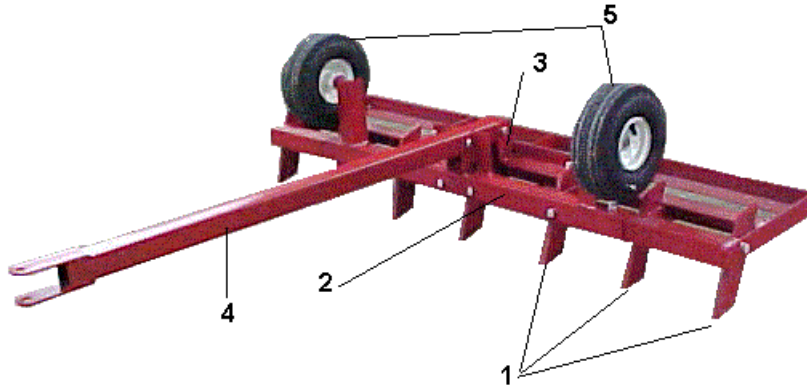

- 1) Bolt on 7 each teeth into slots using hole closest to the center of tooth (other hole is for wear adjustment).
- 2) Bolt on the long angle iron to the front of the ripper frame with welded pipes facing forward.
- 3) Bolt on the short angle iron to the center frame support with flat tabs upward.
- 4) Bolt on the tongue assembly using flat bar tabs.
- 5) Slide wheels onto axles and fasten using 1/8" x 1 1/2" cotter pins.

Note*** Make sure to use the enclosed lockwashers when attaching all bolts. This helps to prevent vibration from loosening the bolts over time.

Fastener List:

15- 1/2" x 1 1/2" bolts	2- 3/4" SAE washers
17- 1/2" nuts	2- 1/2" x 3 1/2" bolts
17- 1/2" lockwashers	2- 1/8" cotter pins



Country Manufacturing, Inc.

P.O. Box 104

Fredericktown, OH 43019

PH: 740-694-9926

FAX: 740-694-5088