

Arena Ripper
Model AR-510
(With 3- Point Attachment)

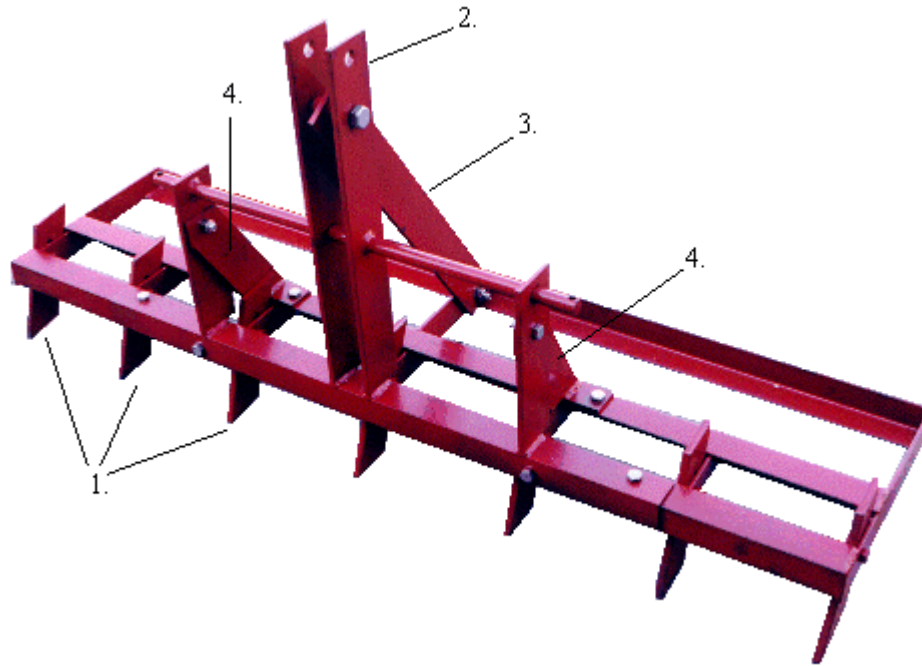

- 1) Bolt on 7 each teeth into slots using hole closest to the center of tooth (other hole is for wear adjustment).
- 2) Bolt on the 3- point attachment hitch to the front of the mainframe. Use 4 each $\frac{1}{2}$ " x $1 \frac{1}{2}$ " long bolts, nuts, and lockwashers.
- 3) Bolt on the "longest" of the remaining pieces to form the middle support brace. Bolt this piece at the top "through" the welded pipe using a $\frac{3}{4}$ " x 4" long bolt. Finally, attach at the bottom using a $\frac{1}{2}$ " x $1 \frac{1}{2}$ " long bolt.
- 4) Attach the remaining flatbar pieces using 2 each $\frac{1}{2}$ " x 1" long bolts at the bottoms; and 1 each $\frac{1}{2}$ " x $1 \frac{1}{2}$ " long bolt at the tops.

Note*** Make sure to use the enclosed lockwashers when attaching all bolts. This helps to prevent vibration from loosening the bolts over time.



Country Manufacturing, Inc.

P.O. Box 104

Fredericktown, OH 43019

PH: 740-694-9926

FAX: 740-694-5088