

Repair Parts

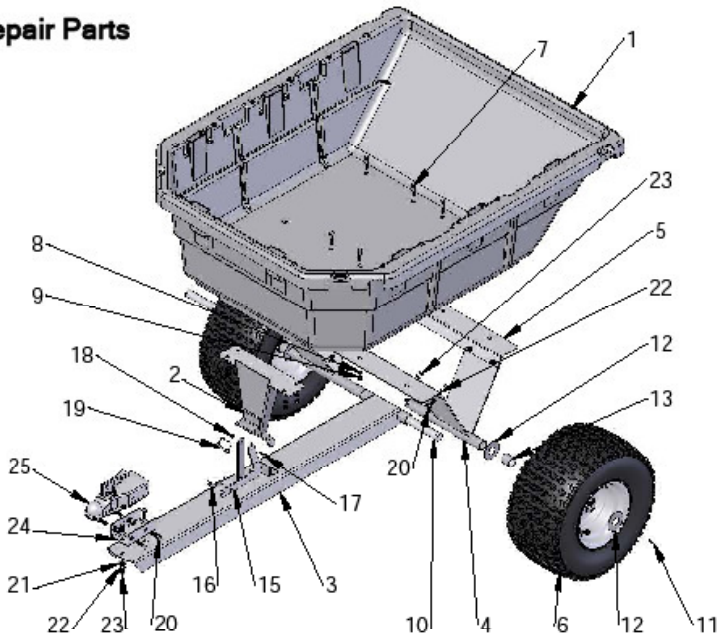

REF. NO.	PART NO.	AMT.	DESCRIPTION	REF. NO.	PART NO.	AMT.	DESCRIPTION
1	4048PATV-01	1	Body	16	4048PATV-16	1	Latch Spring
2	4048PATV-02	1	Front Support	17	STDBH250750	1	1/4"-20 X 3/4" Hex Bolt
3	4048PATV-03	1	Hitch	18	STDNH250	1	1/4"-20 Lock Nut
4	4048PATV-04	2	Axle Holder	19	STDSP2501750	1	1/4" X 1-3/4" Safety Pin
5	4048PATV-05	2	Under Carriage	20	STDBH3751000	14	3/8"-16 X 1" Hex Bolt
6	4048PATV-06	2	Wheel	21	STDFW375SAE	4	3/8" Flat Washer
7	STDBH3131500	12	5/16"-18 X 1-1/2" Hex Bolt	22	STDWSL375	14	3/8" Split Lock Washer
8	STDWSL313	12	5/16" Split Lock Washer	23	STDNH375	14	3/8"-16 Hex Nut
9	STDNH313	12	5/16"-18 Hex Nut	24	HK178-2	1	Hitch Coupler Plate
10	4048PATV-10	1	Axle 4048PATV	25	HK178-1	1	Hitch Coupler
11	STDCP1251500	2	Cotter Pin	30	4048PATV-30	1	Decal -Not Shown
12	STDWA1000	4	1" Axle Washer Thin	31	4048PATV-31	1	User Guide-Not Shown
13	4048PATV-13	2	HDPE Axle Spacer	32	4048PATV-32	1	Hardware Bag-Not Shown
15	4048PATV-15	1	Latch				

*Standard hardware items can be purchased locally.
For missing parts or questions call 1-800-652-2321

- 4 -

Distributed By:
Country Manufacturing Inc.
www.countrymanufacturing.com
1-800-335-1880

POLY ATV CART

- 12.5 cu. ft. heaped capacity.
- 1000 pound weight capacity.
- Durable, structural foam body.
- 1 7/8" Ball hitch coupler.
- Molded slots for dividing loads.
- Center ledge for adding shelf.
- Durable needle bearings for high speed use.
- Molded stake pockets and tie down areas.

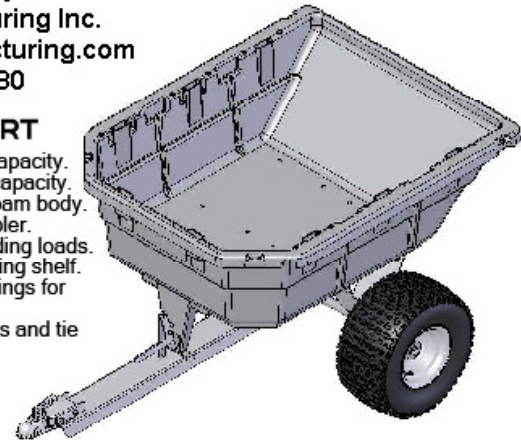

LIMITED ONE-YEAR WARRANTY

If this product fails due to a defect in material or workmanship within one year from the date of purchase, we will at our option repair or replace it free of charge. This warranty excludes tires and wheels, which are expendable and become worn during normal use.

This warranty does not cover:

- Repairs necessary because of operator abuse or negligence.
- Equipment used for commercial or rental purposes.

Proof of Purchase Required For All Warranty Claims.

ORDERING INFORMATION

After the one year warranty period all parts may be ordered by calling 1-800-652-2321.

When ordering repair parts, always give the following information:

- Product - POLY ATV CART
- Model Number - 4048P-ATV
- Part Number - _____
- Part Description - _____

Safety Instructions

- Read user guide before assembly or operation of this utility cart.
- Read owners manual to ATV or lawn tractor before use. Operational use may depend on vehicles.
- Always check hitch coupling is attached properly before use.
- **Do not** carry passengers in cart.
- **Do not** tow cart on public roads.
- **Do not** tow cart at high speeds.
- Cart is not designed to be pulled by cars and trucks.
- Never exceed load capacity - 1000 lbs. When operating on slopes, use lowest ground speed and limit load to 200 lbs.
- Reduce speed when driving over rough terrain.
- Reduce speed when towing heavy loads.
- Braking distance and handling may change while towing cart.
- Avoid sudden turns or maneuvers while towing cart.
- Operate up and down slopes, never across the face.
- Distribute load evenly to prevent loss of control.

Maintenance

- Check tire pressure regularly.
- Periodically check all bolts.
- Keep cart clean to prevent rust.
- Store inside a clean dry area.

Tools Required

- Wrenches and or sockets
- 7/16", 1/2" and 9/16"
- Pliers
- Large blade screwdriver

Load Weights

- Note Max Capacity 1000lbs
- Weight pounds per cubic foot

	Dry - Wet
Dirt	70 - 110 lbs
Sand	90 - 120 lbs
Gravel	100 - 125 lbs

Step 1. Attach latch (15) to latch post on hitch (3) using hex bolt (17) and lock nut (18).

Step 2. Attach latch spring (16) to latch post on hitch (3) and latch (14).

Step 3. Attach hitch coupler (25) to hitch coupler plate (24). Secure with hex bolt (20), lock washer (22) and hex nut (23).

Step 4. Attach hitch coupler assembly (24) to hitch bar. Insert hex bolt (20) through flat washer (21), hitch coupler plate (24), hitch bar (3), flat washer (21), lock washer (22), and hex nut (23). Repeat for second hole and tighten bolts.

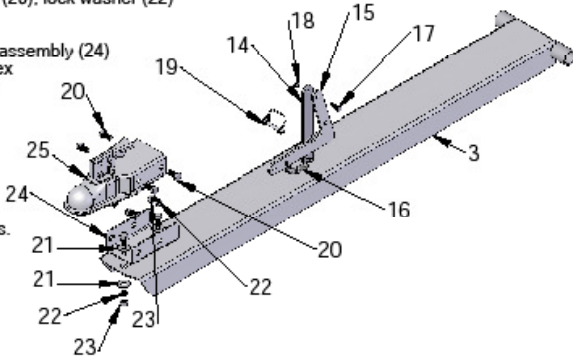

Step 5. Loosely attach axle holders (4) to under carriage (5) using hex bolt (20), lock washer (22), and hex nut (23). **Do not tighten until step 8.**

Step 6. Loosely attach axle holder assembly to body (1) using hex bolt (7), lock washer (8) and hex nut (9).

Step 7. Loosely attach front support (2) to body (1) using hex bolt (7), lock washer (8) and hex nut (9).

Step 8. Slide axle (10) through axle holders (4) and hitch assembly (3) and center. **Tighten bolts from step 5 and 6.**

Step 9. On both sides, slide on an axle washer (12), axle spacer (13), wheel (6), and axle washer (12). Insert cotter pin (11) into axle (10) and bent open ends outward.

Step 10. Attach safety pin (19) on to latch to lock hitch bar (3) in place.

